

## Left Hand Thread Nut

**Thread Type:** Metric Coarse - Left Hand Thread

**Thread Direction:** Left Hand

**Material:** Stainless Steel

**Class Grade:** A4-70 G316

**Corrosion Protection Level:** Ultimate

**Standard:** DIN 934

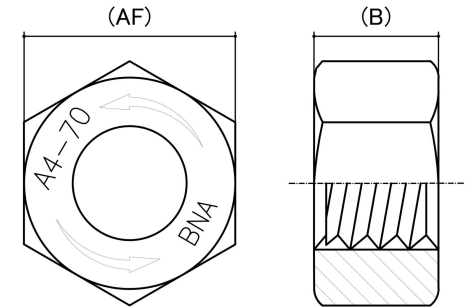

*CAD drawings shown for graphic representation only.\**

Size	Thread Pitch (mm)	Thread Type	Overall Nut Height (B) (mm)		Across Flats (AF) (mm)		Spanner Size (AF) (mm)	sku (qfind)
			Min	Max	Min	Max		
M5	0.80	Left Hand Thread	3.70	4.00	7.78	8.00	8	41SLH5M
M6	1.00	Left Hand Thread	4.70	5.00	9.78	10.00	10	41SLH6M
M8	1.25	Left Hand Thread	6.14	6.50	12.73	13.00	13	41SLH8M
M10	1.50	Left Hand Thread	7.64	8.00	16.73	17.00	17	41SLH10M
M12	1.75	Left Hand Thread	9.64	10.00	18.67	19.00	19	41SLH12M
M16	2.00	Left Hand Thread	12.30	13.00	23.67	24.00	24	41SLH16M

**Disclaimer:**

Dimensional data and technical information was obtained from publicly available sources and not acquired through standard agencies. It has been completed and compiled for reference purposes only; where discrepancies are found they are subject to change without notice. Bolt & Nut Australia makes no warranties or representations regarding the accuracy and validity of the compiled information and data. Contact the relevant standard authorities for accurate and detailed information.

\* CAD drawings may not reflect diameter, thread length or overall length.

© Bolt & Nut Australia Pty Ltd. All rights reserved.

Version: 18 Mar 2024